

Zone 2 Output From MC-2 to TB-MIC Input

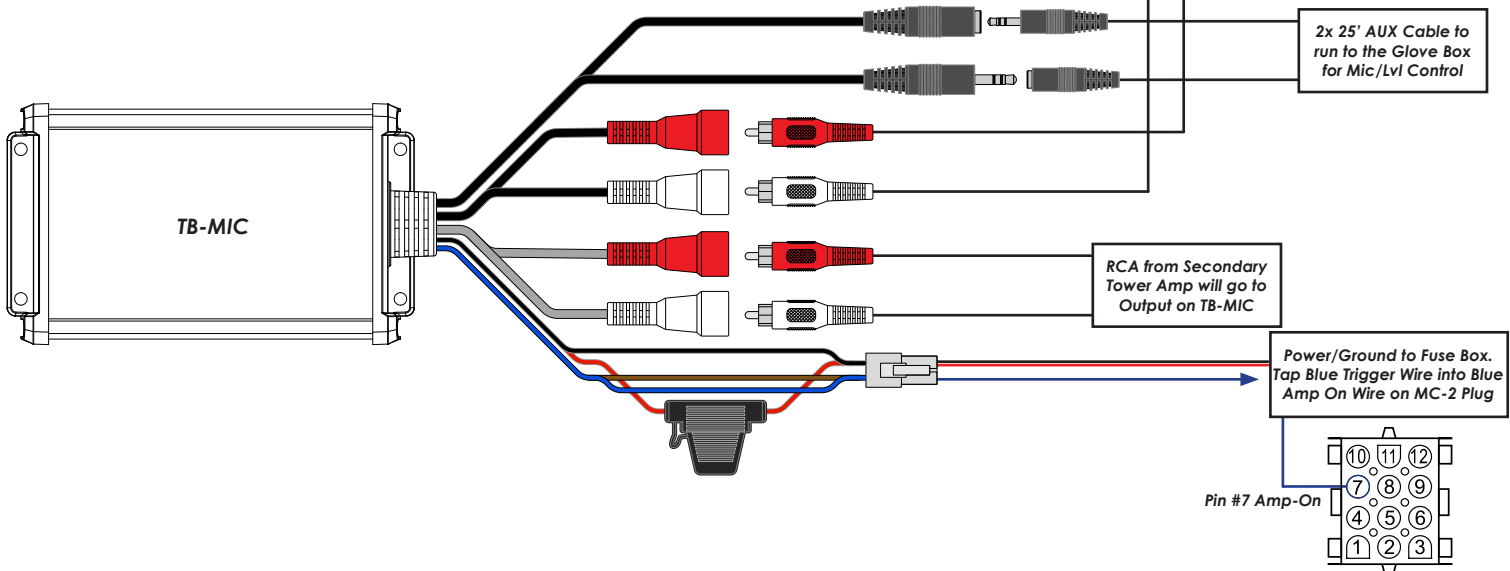



You will need to remove 4 Allen screws to gain access behind the radio. You will have room on both sides of the MC-2.



Wipe area with alcohol let dry then apply double side tape to the Talk Back Mic. mount the unit on the left-hand side add some foam padding to prevent rattle.



Once you have the box secured then time to wire into the MC-2's harness. Wire up Blue to Blue and then extend your power and ground to go towards the back with the Aux Cables.



In order to reach the glove box area or just anywhere up front you will need to purchase two 25ft Aux Cables to make the run.



The Fuse box is in the same area as the secondary amp. There is a 12v output location available. remove cover and place a 2amp fuse in the empty location. And connect your red wire from the talk back mic and ground at any ground post.

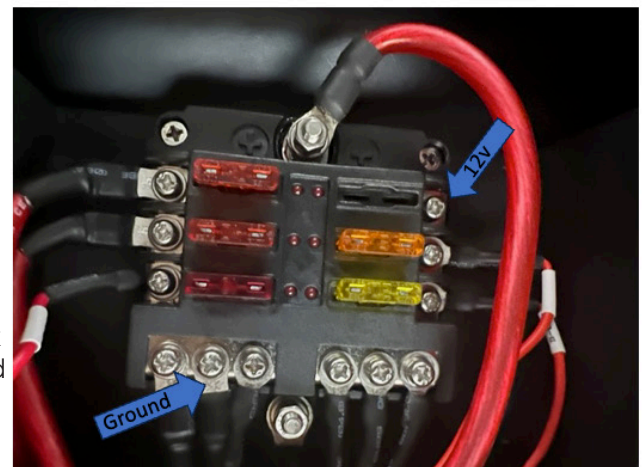



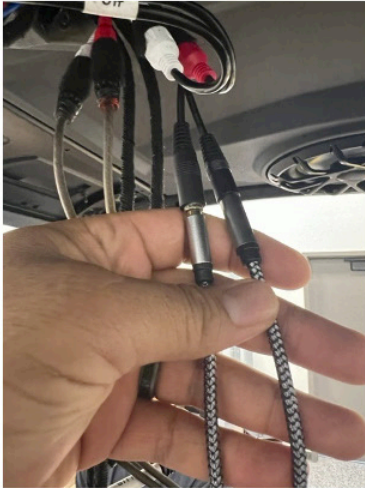

Plug in your 3.5 Aux cables and tape/heat shrink and route them towards the back of the roof with a Long zip Tie or a wire grabber. removing the Secondary amp will make things easier to fish the cables through.



With the amp out you will pull the grommet out some and will need to cut the electrical tape in order to slide the cables into the main harness of the roof. You will tuck the cables in till you get down to the area were its connected to the battery.

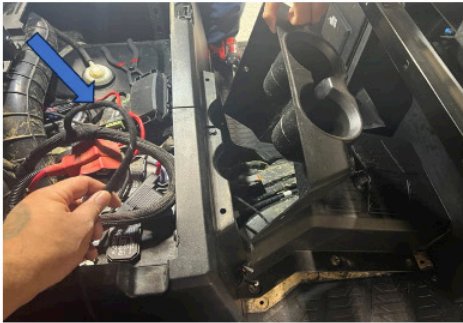

Wrapp the aux cables in tesa tape to make the run easier. There are a few tabs you will need to remove from the cupholder panel. This will allow you to run the cables up front following OEM wires.



Once the rear center console is removed you can run the Aux cables along side OEM wire.



Lift passenger seat and remove tray to gain access and pull the AUX cable from the back.



There is an OEM harness that you can zip tie and run the cables along side it.



Now the front cup holder/center console needs to be removed same process as the rear one.



The center switch panel will need to be removed to gain access to the glove box.



Under the switch panel you will locate 2 tabs to be removed.



Route your cable along side of OEM harness and up into the dash area. In order to make your way to the glove box. Any access wire you can tie up in this area.



Mount the control just shy of the glove box you can and pop 2 holes big enough for the AUX cable to fit through.



The male Aux will go to the controller and the female Aux will go to the Mic. The Mic will reach to the driver area and can still close the glove box. We recommend this location to prevent loss or damage when not in use.